



USER MANUAL

Hydraulic self-centering mobile puller
BETEX[®] HXPC 50 Ton

Contact

Address	Bega International BV Schorsweg 15 8171 ME Vaassen The Netherlands
Tel	+31 (0) 578 668000
Web	www.begaspecialtools.com
Mail	info@bega.nl
ISO	ISO 9001: 2015

Warning!

Read the manual and safety instructions before operating the device

Check all parts for possible damage during transportation. In case of damage, please contact the carrier immediately. Because our products are continuously subject to improvements, we reserve the right to make changes.

Vor inbetriebnahme die betriebsanleitung und die sicherheitsvorschriften aufmerksam lesen

Alle teile auf möglichen transportschaden kontrollieren. Eventuelle schäden umgehend der spedition melden. Da unsere produkte ständig verbessert werden, behalten wir uns änderungen vor.

Antes de la primera puesta en marcha, lea atentamente el manual de uso y las instrucciones de seguridad

Revise todos los elementos para detectar posibles daños sufridos durante el transporte. En caso de observar algún daño, avise inmediatamente a la empresa de transporte. Debido a que nuestros productos están continuamente sujetos a mejoras, nos reservamos el derecho de realizar cambios.

Lisez le mode d'emploi et les consignes de sécurité avant la mise en service

Vérifiez pour l'ensemble des pièces que celles-ci n'ont pas été endommagées pendant le transport. En cas de dommages, avertissez immédiatement le transporteur. Nos produits étant constamment améliorés, nous nous réservons le droit d'apporter des modifications.

Lees voor ingebruikname eerst de gebruiksaanwijzing en de veiligheidsvoorschriften

Controleer alle onderdelen op mogelijke transportschade. Waarschuw bij schade onmiddellijk het transportbedrijf. Omdat onze producten voortdurend worden verbeterd, behouden wij ons het recht voor om wijzigingen aan te brengen.

ENGLISH

Contents

1. Introduction	5
1.1 Application	5
1.2 Inadvisable use	5
1.3 Application areas	5
1.4 Principles of operation	5
1.5 Requirements for user/maintenance personnel	5
1.6 Use of personal protective equipment	5
1.7 User workplace	5
2. Safety	6
2.1 Safety risks	6
2.2 Safety precautions	6
2.3 Safety measures to be observed	6
2.4 Explanation of machine symbols	7
2.5 Position of symbols on machine	7
3. Transport and storage	8
3.1 Transport method	8
3.2 Storage conditions	8
4. Assembly, installation and commissioning	8
4.1 Unpacking and fitting	8
4.2 Assembling and connecting	8
4.3 Initial commissioning	8
4.4 Trial run	8
4.5 Provisions to be supplied by buyer	8
5. Operation	9
5.1 Operation and use	9
6. Cleaning and maintenance	11
7. Decommissioning	11
8. Disclaimer	11
9. Technical data	12
9.1 Technical specifications	12
9.2 Electrical scheme	12
9.3 Hydraulic scheme	12
9.4 Explanation of machine parts	13
10. CE Declaration of Conformity	14
10. UKCA Declaration of Conformity	15

1. Introduction

1.1 Application

- The BETEX HXPC is exclusively intended for removing pulleys, bearings, couplings and other symmetric rotation objects mounted on shafts.
- The BETEX HXPC is solely for use up to a maximum spread of 840 mm and min./max. height of 210/1550 mm (centreline plunger to surface).
- The object may not be wider than 101,6 mm (4") at maximum spread.

1.2 Inadvisable use

- Do not use in areas with a high risk of explosion
- Do not use if the HXPC cannot be positioned in line with the shaft and the object to be removed.
- Do not use if the pressure surface of the shaft is not positioned at a right angle to the pressure surface.

1.3 Application areas

- Industrial environments.
- Do not expose to rain or moisture, humidity < 80%
- Appropriate mains connection, 230V/ 16A/ 50Hz (Reconnecting 120V is possible)
- Ensure that there is a level, horizontal, stable surface, capable of bearing any point loads via the wheels of the puller, which are caused by the weight of the device and the object.

1.4 Principles of operation

- The operation of the HXPC 50 t is based on a hydraulic cylinder which reacts against the outer end of the shaft with the object to be removed. By placing the jaws of the HXPC 50 t behind the object to be removed, this object is shifted axially through the reaction of the cylinder against the shaft end.
- Depending on the application, an adapter can be used between the cylinder and the shaft-end.
- The HXPC 50 t works with a hydraulic pressure of 700 bars maximum. The manometer indicates bar/psi.

1.5 Requirements for user/maintenance personnel

- The user/operator must have sufficient command of the language in which the manual is written to enable him to fully understand the contents of this manual.
- The user must have sufficient technical knowledge. The user must understand principles of operation of the HXPC, and be capable of correctly assessing the potential hazards arising from using the HXPC.

1.6 Use of personal protective equipment

- Use personal protective equipment when using and performing maintenance. Safety shoes for fall hazards, safety glasses for splashes and/or projectiles, hearing protection (81 dB(a)), safety blanket for airborne parts (supplied).

1.7 User workplace

- This must be clean, neat and free of obstacles.

2. Safety

2.1 Safety risks

- External forces on the HXPC resulting in topple hazard.
- Airborne projectiles when the object to be removed is suddenly released or damaged.
- High hydraulic pressure.
- Failure to align parts properly can result in a dangerous operating situation because of the high hydraulic pressure used.
- The risk of damage to the shaft, the jaws and/or the press cylinder and pushing adapters, if the press cylinder is not properly aligned with the shaft holding the object to be removed.
- Elevated temperatures of hydraulic oil and pump during intensive use.
- Damage to the pulling jaws.







2.2 Safety precautions

- The safety blanket supplied is used to prevent damage caused by airborne projectiles as a result of possible damage caused while moving the object. Dimensions: 5800 x 1600 mm

2.3 Safety measures to be observed

- Never rely on this puller to support, carry and/or transport the object being pulled, which differs from the dismantling process.
- Align the puller on the same centerline as the object to be removed.
- Before each use, check the hydraulic hoses for wear and tear or damage. Never touch a damaged or leaking pressurized hydraulic hose.
- Ensure that the electrical cable is not damaged.
- Use the personal protective equipment. See section 1.6.
- Hose material and coupler seal must be compatible with the hydraulic fluid used.
- Always keep the hoses away from fire, sharp surfaces on objects, heavy impact and extreme heat or cold. Never kink, twist, curl or bend the hose so that the oil flow within will be blocked or reduced.
- Hose also must not come in contact with corrosive materials such as creosote-impregnated objects and some paints.
- Never paint a coupler or hose as this may cause deterioration of materials.
- Never use the hose to move attached equipment. The tension can cause damage to the hose. This can result in personal injury.
- Do not adjust the settings of the internal high pressure relief valve. Creating hydraulic pressure beyond rated capacities can result in personal injury and damage to the machine.

2.4 Explanation of machine symbols

	Consult manual		Safety gloves compulsory
	Ear defenders compulsory Safety glasses compulsory		Unplug
	Safety shoes compulsory		Voltage

2.5 Position of symbols on machine



3. Transport and storage

3.1 Transport method

- In parts (to be mounted)
- Internal transport: using own wheels
- External transport: in crate or on pallet
- By air: drain oil from the pump.

3.2 Storage conditions

Temporary:

- In final position
- Store in a clean and dry environment.
- Apply brake.

Decommissioning:

- In final position
- Store in a clean and dry environment.
- Use a plastic cover to protect from dust (optional).

4. Assembly, installation and commissioning

4.1 Unpacking and fitting

- Place the pallet or crate on a stable, level, horizontal surface, capable of bearing the weight of the puller and the object.
- Remove packaging materials.
- Check all parts for possible transport damage. If any damage is apparent, inform carrier immediately.
- Check whether safety blanket has been supplied.
- Remove the parts BETEX HXPC from the pallet.
- The entire frame must be supported if hoisting devices are used.
- Ensure that the hydraulic hoses do not become jammed.

4.2 Assembling and connecting

- Fill the pump to ± 2 cm under the top of the reservoir with the supplied hydraulic oil.
- Connect the pump to the power supply specified on the machine plate.
- Mount puller to crane.
- The HXPC is ready to use.

4.3 Initial commissioning

- Ensure that the electrical connection is correct and that the electric hydraulic pump is connected.
- Before each use, check the hydraulic hoses for wear and tear or damage. Damaged hoses should be replaced immediately.

4.4 Trial run

- Performing the maximum cylinder stroke once prior to use is recommended. See section 5.1.
- Check the correct operation of the safety valve.

4.5 Provisions to be supplied by buyer

- Personal protective equipment. See section 1.6.
- Lifting and hoisting devices/gear.

5. Operation

5.1 Operation and use

WARNING!



- Never touch a pressurized hydraulic hose that is damaged or leaking. This can result in personal injury.
- Never use the hose to move attached equipment. The tension can cause damage to the hose. This can result in personal injury.
- Never heat the object being removed when the puller is connected to the object. Heat can damage parts of puller. Never expose the jaws to heat or naked flame.
- Do not try to pull objects that exceed 101.6 mm (4") in thickness at the max. opening of 860 mm or require the jaws to open more than 860 mm (33").
- Always use the 3-arm combination whenever the working situation permits this. Three arms give a more secure grip and a more even pulling force.

Conversion of 3-jaw puller to 2-jaw puller

Remove both jaws and the straps which are located between the symmetrical recesses.

Reassemble one jaw and straps set symmetrically to the other set on the crosshead.

Tools required: key wrench 2x size 40 and 2x size 27.

1. Ensure that the electrical connection is according machine plate and that the electric hydraulic pump is connected.
2. Ensure the overload/pressure relief valve handle is in original locked position.
3. Adjust vertical set-up by remote control of the pump.

NOTE!!! The centerline of the object being pulled must be on the same centerline as the puller head.

4. Align the puller on the same centerline as the object to be removed. Failure to align parts properly can result in a dangerous operating situation because of the high hydraulic pressure used. This self-centering model can be aligned on the centerline after the puller jaws are fully engaged with the object.
5. Align the puller jaws and pushing adapter set-ups on the same centerline as the object to be removed.
Failure to align parts properly can result in a dangerous operating situation because of the high hydraulic pressure used.

WARNING!



- Do not apply wheel brakes during removal, as the puller moves backwards.

Height adjustment:

- **Lifting:** Set the pump handle on 'ADV'. Set the external valve handle to 'Lift' and start pumping to lift the machine.

NOTE!

By switching the external valve the machine drops a little. We advise to set the height slightly higher to compensate

- **Lowering:** Set the pump handle to 'ADV'; Set the external valve handle to 'Lift'. If you put the handle to 'RET' the machine is lowering.

To use the puller

1. Turn the screw to open the jaws enough to fit around the object
2. Slide the puller jaws across the object to be removed.

WARNING!



- Ensure that the object never rests on the puller. The weight can cause the HXPC to topple.
- Do not place slings around the jaws, only around the object to be removed.

3. Turn the screw to close the jaws.
4. Check that the alignment is correct, if not repeat steps.
5. Add as many adapters as practical to the press cylinder.
6. Set the external valve to 'Press'. Set the handle of the pump on 'ADV' and start pumping. The cylinder now extends.
7. The puller is correctly aligned. Press the button on the remote control to advance the plunger with pushing adapter towards the object until the pushing adapter comes into contact with the shaft.
8. As soon as the pushing adapter contacts the shaft, release the button and inspect the puller and object again for proper alignment.
9. Provide external support for the object to be removed. For example: crane or lift table.
10. Place the safety blanket over the object.
11. Stand behind the puller to the left, where you have a clear view of the manometer. Continue with pulling job by pressing the button on remote control.
12. The cylinder is fully extended and the pulling job is not fully completed. Set the handle of the pump on 'RET'. The cylinder now retracts. Fit an extra pushing adaptor while maintaining the gripping action of the jaws on the object. Reposition the blanket if it moves.
13. Continue with pulling job by setting the handle of the pump on 'ADV' and start pumping.

The pulling job was successful.

Set the handle of the pump on 'RET'. The cylinder now retracts.

WARNING!



- Falling objects can cause personal injury.

The pulling job was not successful.

The pulling job was not successful, the pressure is 700 bar (10.000 psi), the object remains in original position. The puller is not suitable for this pulling job.

6. Cleaning and maintenance

- Only by authorized users (as described in section 1).
- Remove the plug from the socket.
- Ensure that the entire system is depressurized.
- Fully retract the cylinder before changing oil to prevent overfilling with oil. An overfill can cause personal injury due to excess reservoir pressure created when cylinders are retracted.
- Check that all pivoting parts are properly lubricated and reapply where necessary; lubricate all pivoting parts at least once a month.
- Check oil level and top up if required. Only use the original hydraulic oil to top up the hydraulic system

7. Decommissioning

All materials must be disposed of in accordance with statutory regulations.

- Depressurize the system
- Ensure that the press cylinder is retracted (spring tension)
- Remove oil
- Cut plug from cable
- Or: return to supplier

8. Disclaimer

The manufacturer and/or supplier cannot be held liable for any damage or consequential damage resulting from incorrect use of the device or damage to workpieces and any consequential damage resulting from a defect in the device.

9. Technical data

9.1 Technical specifications

Type	HXPC 50T
Art. no.	700016
Capacity ton	50
Max. stroke length mm	159
Max. spread mm	860
Min. spread mm	160
Max. shaft length mm	455
Operating main cylinder Operating height adjustment	Electro-hydraulic pump, 230V-5A-50/60Hz or 120V-10A-50/60Hz, with remote control
Operating self-centering jaws	Manual
2 adapters, total length: 310 mm	1 x \varnothing 40: length 155, 1 x \varnothing 50: length 155
Min. height (from the centre) in mm	210
Max. height (from the centre) in mm	1550
Manometer bar	700
Dimensions mm LxWxH	1850 x 970 x 1550
Weight kg	280

9.2 Electrical scheme

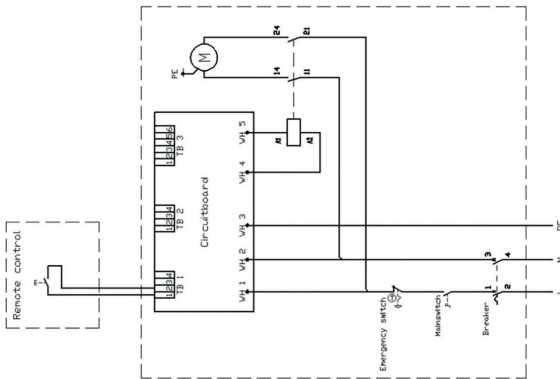

9.3 Hydraulic scheme

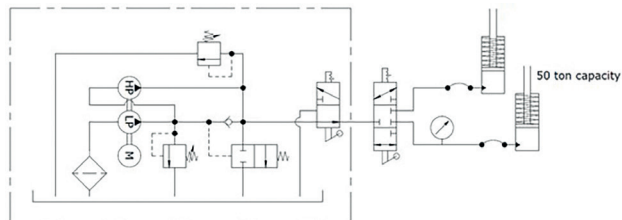

9.4 Explanation of machine parts

50 TON EASY PULLER MODEL:PRE50T

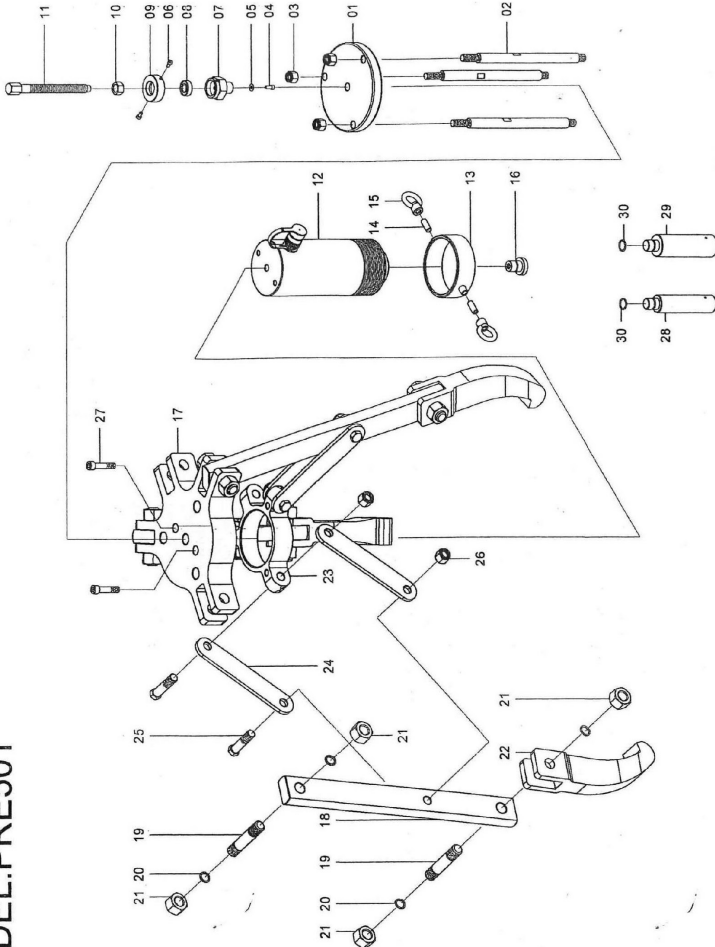

REF. NO.	PARTS NO.	DESCRIPTION	QTY
01	E1924	Fixed Plate	1
02	E1925	Pulling Shaft	3
03	H0165	Anti-Loosen Nut	3
04	H0048	Screw	1
05	H0297	Washer	1
06	H0036	Screw	2
07	E1926	Bearing Socket	1
08	K0051	Bearing	1
09	E1927	Driving Cover	1
10	H0074	Nut	1
11	E1928	Driving Shaft	1
12	PRE506	Cylinder	1
13	B1056	Ram Fixed Assem.	1
14	H0399	Screw	2
15	H0065	Ring	2
16	B1056	Removable Cone Assembly	1
17	F0320	2/3-Way Puller Crosshead	1
18	C1119	Puller Jaw	3
19	H0314	Screw	6
20	J0272	Spring Washer	12
21	H0202	Nut	12
22	F0357	Jaw Head	3
23	F0356	2/3-Way Sliding Socket	1
24	C1120	Puller Jaw Strap	6
25	E1747	Screw	6
26	H0348	Anti-Loosen Nut	6
27	H0347	Screw	2
28	E1875	Extension Bar A	1
29	E1876	Extension Bar B	1
30	G0240	O-Ring	2
31	CP382	Coupler	1
32	M0057	Safety Blanket	1

JR50T500E11

10. CE Declaration of Conformity

CE Declaration of Conformity

Manufacturer's name: Bega International BV
Manufacturer's address: Schorsweg 15, 8171 ME Vaassen, NL
www.begaspecialtools.com

Hereby declares that the following products:

- BETEX HXPC 50T

are in conformity with the requirements of:

- Machine Directive 2006/42/EC
- Low Voltage Directive 2014/35/EU
- EMC Directive 2014/30/EU

Where applicable, the following harmonised standards have been applied:

- EN-ISO 12100:2010
- EN-ISO 4413:2010

Vaassen, 01-12-2022

H. van Essen,
Managing Director
Bega International BV



10. UKCA Declaration of Conformity

UKCA Declaration of Conformity

Manufacturer's name: Bega International BV
Manufacturer's address: Schorsweg 15, 8171 ME Vaassen, NL
www.begaspecialtools.com

Hereby declares that the following products:

- BETEX HXPC 50T

are in conformity with the requirements of:

- The Supply of Machinery (Safety) Regulations 2008 S.I. 2008:1597
- Electrical Equipment (Safety) Regulations 2016 S.I. 2016:1101
- Electromagnetic Compatibility Regulations 2016 S.I. 2016:1091

Where applicable, the following harmonised standards have been applied:

- BS-EN-ISO 12100:2010
- BS-EN-ISO 4413:2010

Vaassen, 01-12-2022



H. van Essen,
Managing Director
Bega International BV



